



Triple Monitors Arms – F-T-Spring





Triple Monitors Arms – F-T-Spring

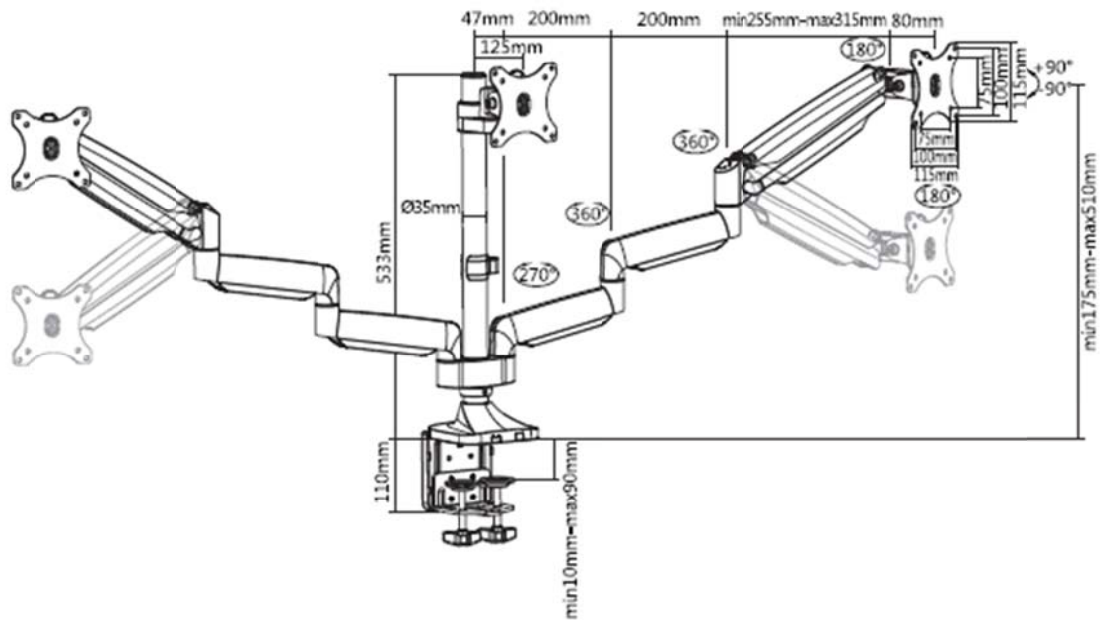

Model: F-T-Spring (**Spring Mechanism**)

Type: Grommet and Clamp

Colour: Silver

Specifications:

***Screen weight range (1kg~9kg)**

***Integrated tool kit**

*Single monitor support with double arms linked

*Screen quick release type

*Cable Management

*180° monitor rotation, tilting +90° ~ -40° (**screen can be tilted to flat**)

*Available with both 75mm and 100mm VESA brackets

*Laptop holder as an option (mounting of laptop)

*Clamp and Grommet Parts supplied together